

SLANVERT

SBH Series

3-11 kV Series Medium-voltage Drive



SLANVERT

Site: www.slanvert.com

Add.: No. 1599, Section 2, 2nd Airport Road, Xihanggang,
Shuangliu district, Chengdu, Sichuan, P.R. China

Email: info@dlhope.com

Tel: +86 028 8565 3587



About Us



Founded in 1998, SLANVERT is a leading enterprise in the fields of energy conservation, environmental protection, new energy, transmission control, and intelligent equipment in China. The company has been honored with recognitions such as China Top Brand, China Well-known Trademark, Ministry of Industry and Information Technology's Specialized, Refined, Differential, and Innovative "Little Giant" Enterprise, and China's number one brand of domestic drive. SLANVERT integrates R&D, manufacturing, system integration, and customer service. Its products include medium and low voltage frequency conversion control systems, automatic production lines, robot drive control, EPS power supplies, port shore power supplies, multi/single crystal silicon power supplies, and other industrial power systems. It provides system solutions for industries such as electricity, building materials, papermaking, municipal services, non-ferrous metallurgy, petroleum and petrochemicals, equipment manufacturing and intelligent manufacturing, ports and airports, rail transit, new energy, and charging clusters.

The company has fully implemented ERP information management, owns a system of independent intellectual property rights composed of over a hundred patents and proprietary technologies, and is certified by ISO 9001:2015 international quality system, ISO 14001:2015 environmental management system, ISO 45001:2018 occupational health and safety management system, and GB/T 29490 intellectual property management system. Its products have obtained certifications such as CE certification in the EU, UL certification in the United States, and EAC certification in Russia.

Adhering to the business philosophy of "excellence without borders, hope infinite", SLANVERT has achieved excellence in quality through over 20 years of focus and dedication. Its products are distributed across more than 30 countries and regions, including China, India, South Africa, Brazil, Italy, Denmark, Singapore, Indonesia, Malaysia, Vietnam, Turkey, among others.

Chengdu Hope Electronics Research Institute was established, and Power Drive System (PDS) and related products R&D were started

1995

The first SLANVERT drive came into the market

1998

SLANVERT launched the first generation of medium-voltage frequency drive

2003

SLANVERT was awarded the title of "China Top Brand"

2007

The new SLANVERT Electronic Industrial Park officially commenced operations and was recognized as a "China Well-Known Trademark" by the State Administration for Industry and Commerce

2013

SLANVERT developed China's first multi-unit parallel medium-voltage frequency drive shore power supply

2018

SLANVERT was listed among the Ministry of Industry and Information Technology's Specialized, Refined, Differential, and Innovative "Little Giant" enterprises

2021

The Xinjin Intelligent Manufacturing Industrial Park was officially put into operation

2023

Qualification Certificate

- National "Little Giant" enterprises
- China Well-known Trademark
- Top 10 Brands of China Electrical Appliance Industry
- Annual Enterprise in China's Automation Field
- Benchmark Enterprise for Customer Satisfaction in China's Electrical Appliance Industry
- The Leading Brand in Chinese Electrical Appliance Industry
- Most Influential Enterprise in China's Electrical Appliance Industry
- Member Unit of the National Variable-frequency Regulating Speed Committee (2017-2022)
- Top 10 Annual Most Influential Engineering Project
- ISO9001 International Quality System Certification
- ISO14001 Environment Management System Certification
- ISO45001 Occupational Health and Safety Management System Certification National Torch Program Project
- National high-tech enterprise
- Top 10 Annual Most Trusted Products by Users
- National Excellent Torch Program Project
- Satisfactory Benchmarking Enterprise of the Users of Chinese Electrical Appliance Industry
- Vice Chairman Unit of Frequency drive Branch of China Electrical Equipment Industrial
- Association Postdoctoral workstation for scientific research



Product Introduction

It is a mature and reliable versatile medium-voltage drive, featuring a modular design that meets the requirements of high efficiency and high reliability applications, with wide adoption in different industries

The SBH series high-performance drive adopts a classic design with integrated transformer and power unit cascading to achieve direct medium-voltage output. The drive utilizes multiple rectifications to meet IEEE/GB grid harmonic requirements, producing an output voltage quality very close to an ideal sine wave, allowing it to drive almost any type of motor (old or new, low-speed or high-speed, asynchronous/synchronous, or permanent magnet). The modular design enables bypassing any unit during operation, ensuring the highest availability of equipment. High-performance vector control makes the drive suitable for various load types such as fans and pumps, variable torque, and constant torque, while the drive is equipped with multiple built-in functions including power loss auto-restart, synchronized switching, flying start, master-slave control, and more. These features make the drive widely used across industries like metallurgy, cement, petroleum and petrochemicals, municipal industry, mining, equipment manufacturing, and others.



- Power rating: 6kV 200-7900kVA, 10kV 250-12500kVA
- Cooling method: Air-cooled, water-cooled
- Key features: Medium-voltage vector drive based on two/four quadrants, synchronous/asynchronous machine control platform design, with unit cascading architecture for bypassability
- Application areas: Energy-saving applications for fans and pumps in the petrochemical, electricity, chemical, metallurgy, building materials, and municipal sectors; process applications such as compressors, belt conveyors, hoists, ball mills, and variable frequency soft starters
- Competitive advantages: High efficiency, high power factor, low harmonics, high-performance vector technology, modular design

Optimized fan cover structure, added fan temperature protection, coordinated with fan control board, realizing fan overload, 3-stage overload, over-temperature, fan contactor malfunction, phase loss, life warning, temperature closed-loop control, fan redundant control protection functions.

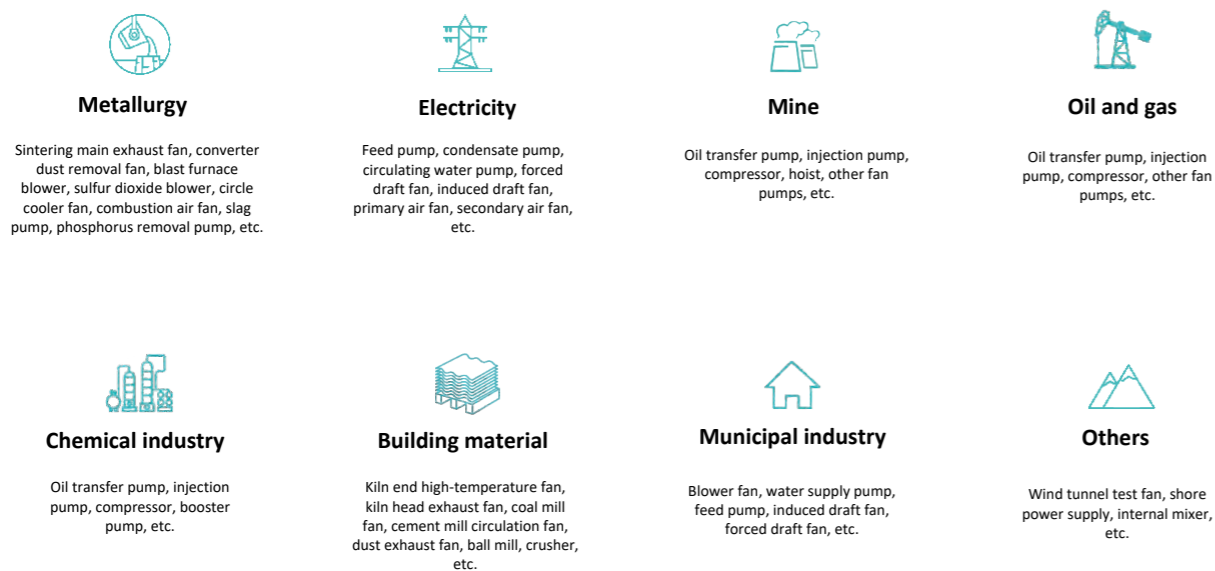
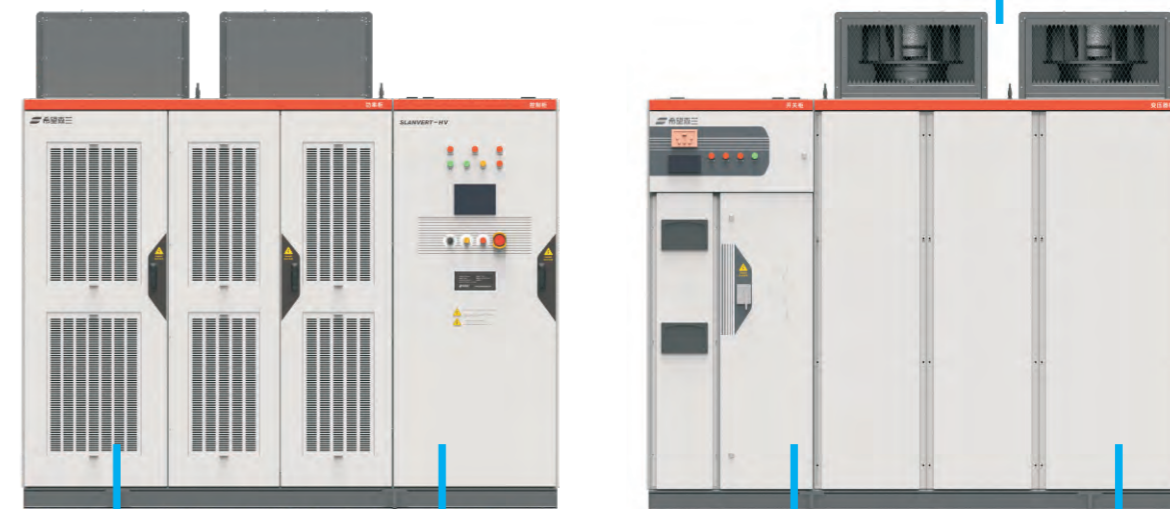

The new power cabinet design increases the air inlet area and cabinet door strength; innovative semi-sealed structure design enhances environmental adaptability and reliability.

The architecture of the integrated machine control cabinet is consistent with the original standard main control system, improving the uniformity of spare parts in the field, while optimizing details within the control cabinet to make on-site operation more convenient; the internal details have been optimized to enhance anti-interference capabilities.

Integrated design for the bypass cabinet, without changing the product installation dimensions, can include manual bypass/automatic bypass/no bypass/isolation/manual bypass with current limiting.

The transformer cabinet and power cabinet adopt a front-to-back layout scheme, which, through advanced thermal design, reduces installation space on-site while ensuring heat dissipation, thereby reducing infrastructure costs for customers.

Reliable durability—extremely low failure rate

Strict component selection and most comprehensive tests are implemented to ensure the reliability of the entire machine. From the product design process to the production process, SLANVERT ensures that each product meets the design requirements and customer on-site process application needs;

Rigorous component selection design are followed; all core components undergo strict testing and selection, with high-quality and long-life products as well as high-quality domestic and foreign brand components being used;

Advanced factory test conditions and test content: domestically leading medium-voltage drive specialized multi-function full-voltage full-load test platform, every product undergoes a series of tests such as withstand voltage, functionality, aging, twin trawling, full-load circulation, etc.

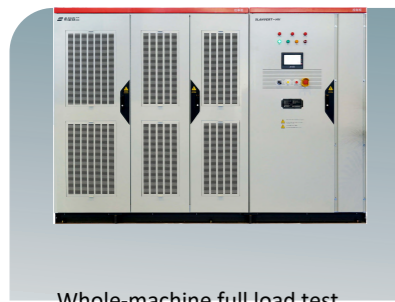

Whole-machine full load test



Motor twin trawling test platform



Power unit intelligent testing system

Typical bypass technology

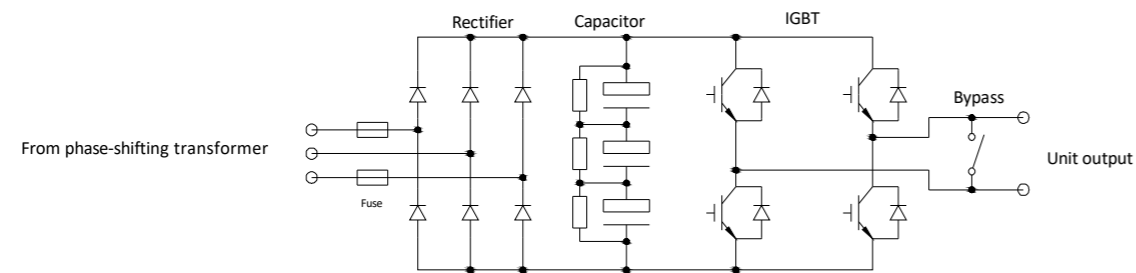

Same level bypass

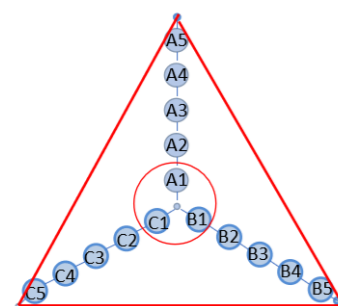

Neutral point offset bypass

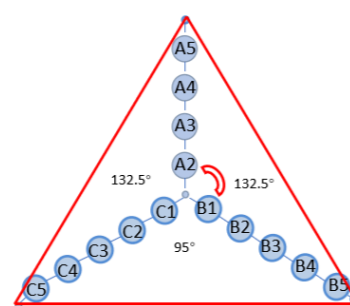

Strong grid adaptability

The SBH series products support national LVRT (low voltage ride through) and HVRT (High voltage ride through) technology.

For fan-type loads, the SBH series medium-voltage drive provides instant power loss protection. When power grid voltages experience waveform deficiency due to lightning strikes or momentary faults, the anti-"voltage flicker" technology prevents equipment from experiencing under-voltage shutdown due to momentary power loss.

In addition, in the event of short-term (0-30s) power loss, the SBH series medium-voltage drive can record the equipment's current operating state and automatically restore to the pre-power loss state upon the grid's power restoration.

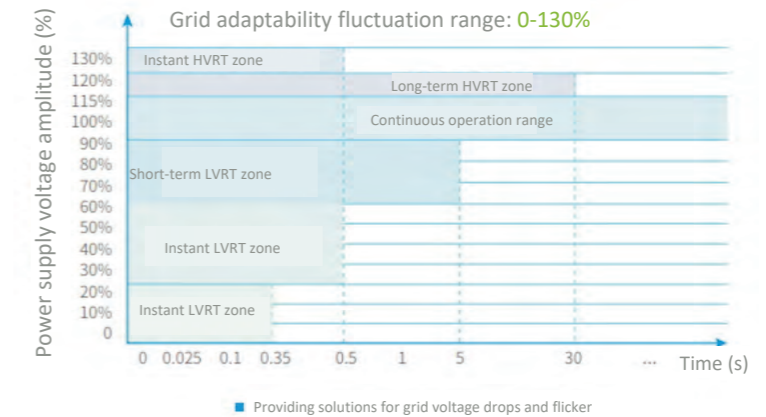

Speed tracking technology—motor non-stop start

The start-up technology suitable for large inertia load is essential for large drag systems, especially in fan applications where the rotor and equipment have large rotary inertia. The free stop time from rotating to a stop varies from tens of minutes to several hours. If the drive loses power due to grid issues, mistakes, or random interferences and powers back on while the motor rotor is still rotating, if the drive can only start when the rotor is at a standstill, it will cause the entire system to shut down or the unit to trip off. For a large system, an unexpected shutdown can result in incalculable economic losses.

The SBH series achieves this by detecting the stator current generated after the motor is injected with search voltage, extracting the torque current components, indirectly observing the rotor frequency through torque current components. It can quickly identify the motor speed and can directly start the motor even if it is in reverse, forward, or a stationary state, driving the motor to the target frequency, ensuring the user's production continuity.

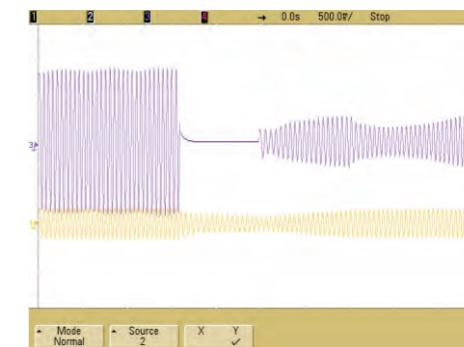

"Fly" start output voltage (current) waveform diagram

Advanced master-slave control—load distribution technology

In the application of drive synchronous speed control technology, multiple motors are often required to drive the same load simultaneously. Choosing the correct synchronous control scheme is a key factor for the synchronous operation of the variable-frequency speed control system. Depending on the specific field process, different variable frequency control schemes can be selected. Synchronous operation of motors requires establishing a certain relationship between the speed control of each motor to ensure coordination in speed and torque among the motors.

Master-slave control synchronous operation of the variable frequency system is achieved through independent multiple drive using master-slave synchronous communication to ensure balance in the speed and torque of multiple motors. Any motor can act as the master, with the remaining motors serving as slaves.

In a master-slave control scheme, the inverters can independently control the torque of the motor. Fiber optic communication is used for communication between master and slave drive, providing strong anti-interference capability and high communication speed. By establishing a reasonable load distribution relationship among motors for synchronous operation, the full output torque control capability of each motor is utilized. The master and slave drive can automatically adjust their respective output speed and torque.

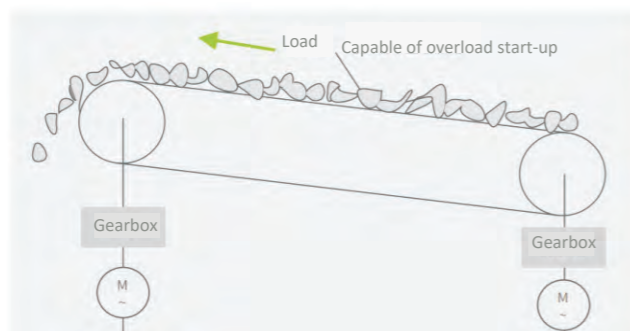

Vector control technology—high-performance process applications

The SBH series, with an algorithm tailored for medium-voltage high-power motors, utilizes a flux linkage closed-loop vector control based on stator magnetic field orientation to achieve high performance. It overcomes sensitivity to rotor parameters and is suitable for both energy-saving applications with square torque loads and process applications with constant torque loads;

The flux linkage closed-loop vector control algorithm ensures that the parameters of the motor will not be affected after long-term operation, resulting in a more stable operation. It guarantees the efficient operation of the motor, greatly increasing system efficiency.

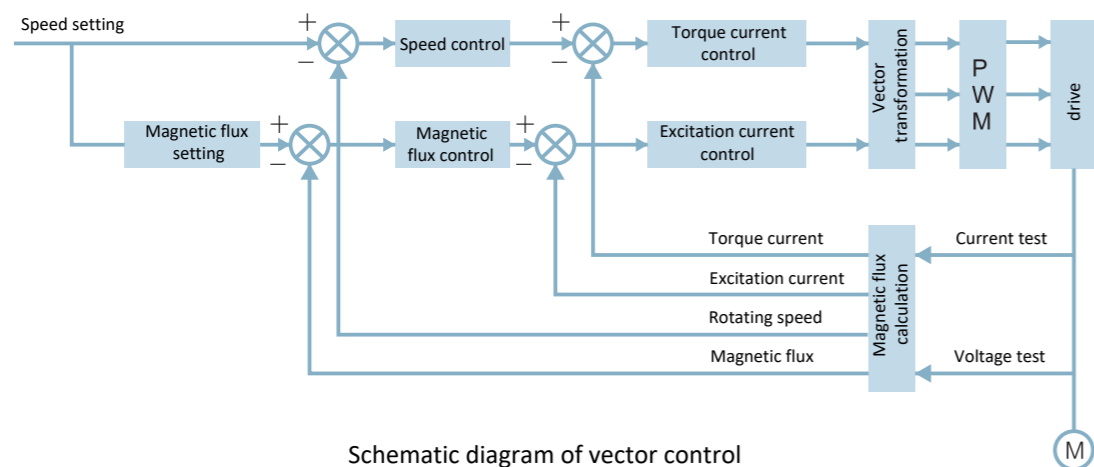

Schematic diagram of vector control

Outstanding heat dissipation air duct solution

The design of a series-connected air duct is adopted, where all incoming cold air first passes through the radiator of the power unit, then through the enclosed transformer duct, and finally exhausted from the cabinet by the top fan, meeting the cooling requirements while reducing the volume.

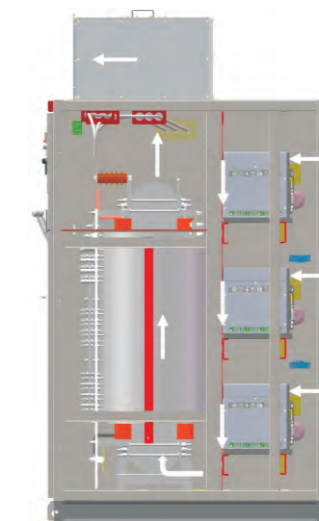

Modular power unit design

- A brand-new power unit design is adopted, which is more compact and aesthetic compared to the original product. The plastic shell unit is lighter in weight with good insulation performance, enhancing its environmental adaptability and reliability.
- Dual-redundant bypass function is configured, so that when a power unit failure occurs, it is first bypassed electronically to maintain rapid response. If the electronic bypass fails, the mechanical bypass is activated to ensure the reliability of the operation.
- This product has a powerful overload capability. Compared to other current brands in the industry where the power unit capacitor design has a smaller margin, typically only 30uF/A current, this product's integrated machine design margin is more than 1.5 times that of the industry standard, ensuring the product's ability to resist disturbances in the power grid.

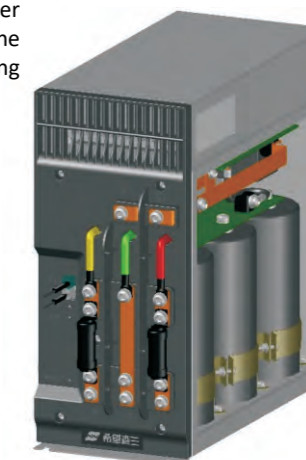

- Supporting dual bypass function for units
- Maximum increase in core component lifespan by 100%
- Integrated PCBA, ALL-in-one module
- Internal cable connections reduced by 85%, significantly reducing potential failure points and enhancing system stability

Control System

The control part of SBH series medium-voltage converter is composed of 32-bit floating point digital signal processor DSP, special large-scale integrated circuit FPGA, large screen color HMI and programmable controller. The DSP implements motor control algorithms, which is specially designed for large-scale integrated circuits for multi-level PWM control; the HMI enables information exchange between medium-voltage frequency conversion devices and users, providing multilingual graphical interface; and the programmable controllers are to process various complex logic controls within the drive.

The control system is the core control unit of the drive, which not only coordinates the work and control of all power units, but also realizes various protection functions of the motor and drive itself. It also performs input and output signal controls of switching and analog quantities with the user control system.

The high speed fiber-optic communication is used between the control system and the power unit to ensure complete electrical isolation between the control system and the medium-voltage power supply. The system features extremely high safety and anti-jamming capability.

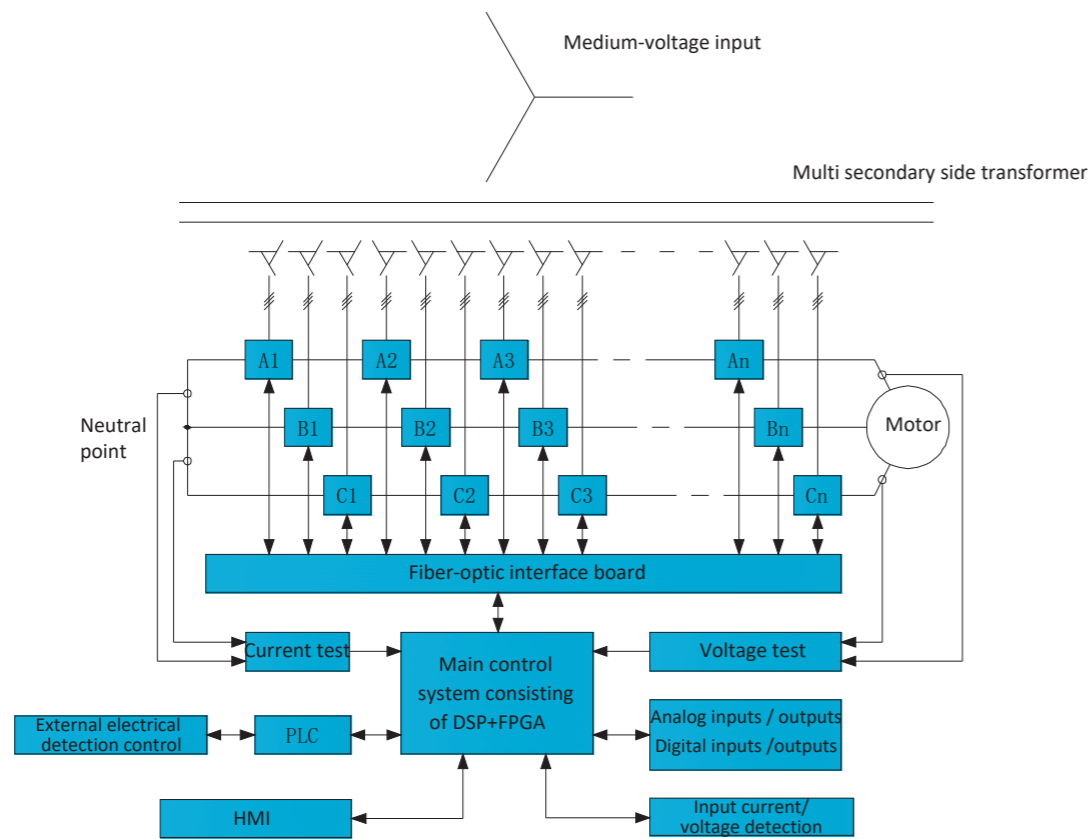

Principle Block Diagram of SBH Series Medium-voltage drive Control System

Typical Scheme

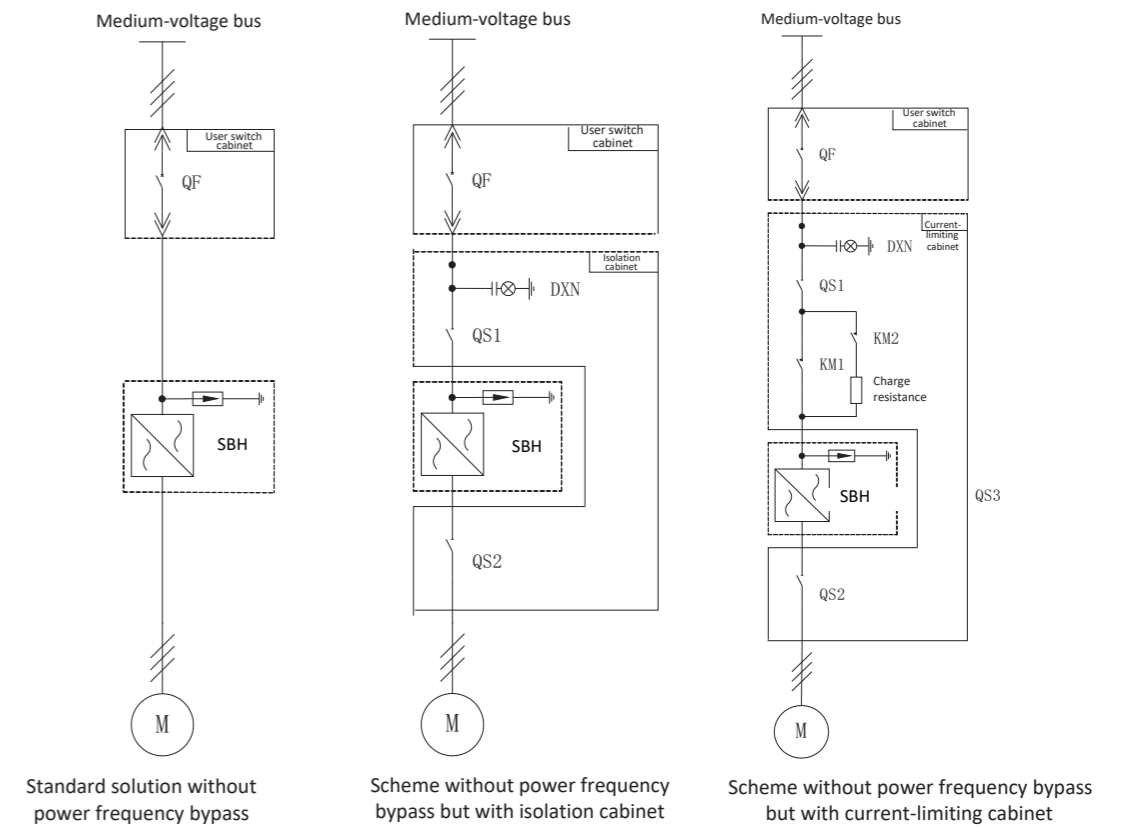

Standard solution without power frequency bypass

QF is the user's superior medium-voltage switchgear
 It is a one-for-one bypass scheme without power frequency, suitable for loads requiring no high continuous operation and not directly started at power frequency. When there are no special requirements, this preparation plan can be used.

Scheme without power frequency bypass but with isolation cabinet

QF is the user's superior medium-voltage switchgear
 This is a one-for-one isolation cabinet scheme without power frequency, suitable for loads not requiring high continuous operation and not directly started at power frequency. It is equipped with an isolation cabinet, which can facilitate the maintenance of drive.

Scheme without power frequency bypass but with current-limiting cabinet

QF is the user's superior medium-voltage switchgear
 It is a one-for-one current-limiting cabinet scheme without power frequency, suitable for loads requiring no high continuous operation and not directly started at power frequency. This scheme is suitable for sites with larger motor power levels (above 4000kW) or smaller system grid capacity.

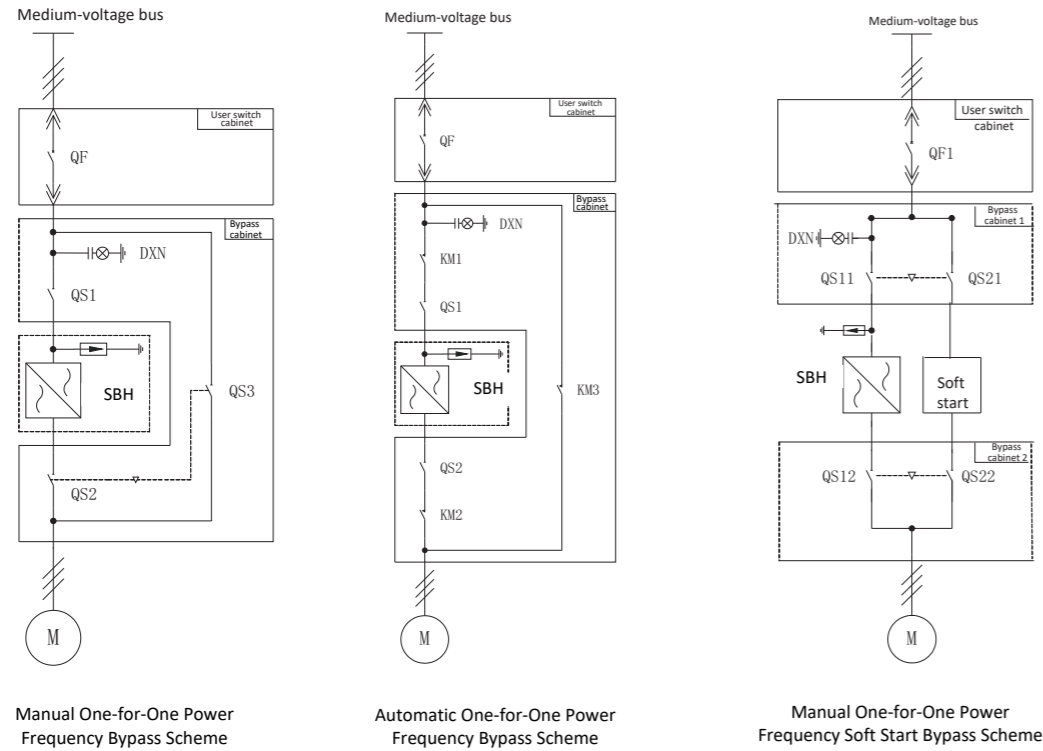

Manual one-for-one power frequency bypass scheme

The QS1, QS2, and QS3 are medium-voltage disconnectors which form a bypass cabinet; and the QF is the higher-level medium-voltage switchgear. The QS2 and QS3 are mechanically interlocked.

This solution is a manual one-for-one frequency bypass scheme, suitable for loads with high continuity requirements and can be directly started at power frequency. This scheme achieves manual switching between variable frequency operation and power frequency operation through QS1, QS2, and QS3.

Automatic one-for-one power frequency bypass scheme

The QS1 and QS2 are medium-voltage disconnectors; the KM1, KM2, and KM3 are medium-voltage vacuum contactors. The two disconnectors and the three vacuum contactors form a bypass cabinet, and the QF is the user's superior medium-voltage switchgear. The KM2 and KM3 are electrically interlocked.

This is an automatic one-for-one power frequency bypass scheme, suitable for loads requiring high continuity and direct startup at power frequency. This scheme achieves automatic or DCS control switching between variable frequency operation and power frequency operation through KM1, KM2, and KM3, ensuring continuous load operation.

It is mainly targeted at air blower load applications.

Manual one-for-one power frequency soft start bypass scheme

The QS11, QS21, QS12, and QS22 are medium-voltage disconnectors; the QS11 and QS21 form bypass cabinet 1, the QS12 and QS22 form bypass cabinet 2, and the QF is the user's superior medium-voltage switchgear.

The QS11 and QS21 are mechanically interlocked, the QS12 and QS22 are mechanically interlocked, and the disconnector of the interlocking circuit can only close one of them.

This is a manual one-for-one power frequency soft start bypass scheme, suitable for loads with high continuity requirements and on-site medium-voltage soft start.

This scheme achieves switching between variable frequency operation and power frequency operation through QS1, QS2, QS3 and QS4.

Dual MVD Hot Redundancy

Two MVDs exchange data in real time. If either converter malfunctions, the system can quickly switch to the other MVD in ms class, making it ideal for critical load applications.

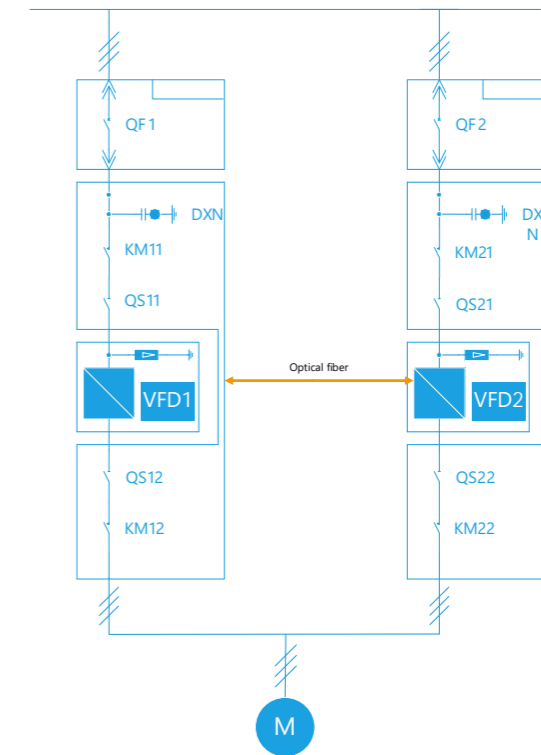

MVD 2 Controller Hot Redundancy

When the MVD is working, both controllers work simultaneously. If either controller malfunctions, it quickly switches to the other controller, with a switching time in the nanosecond range. This is suitable for applications with high system stability requirements.

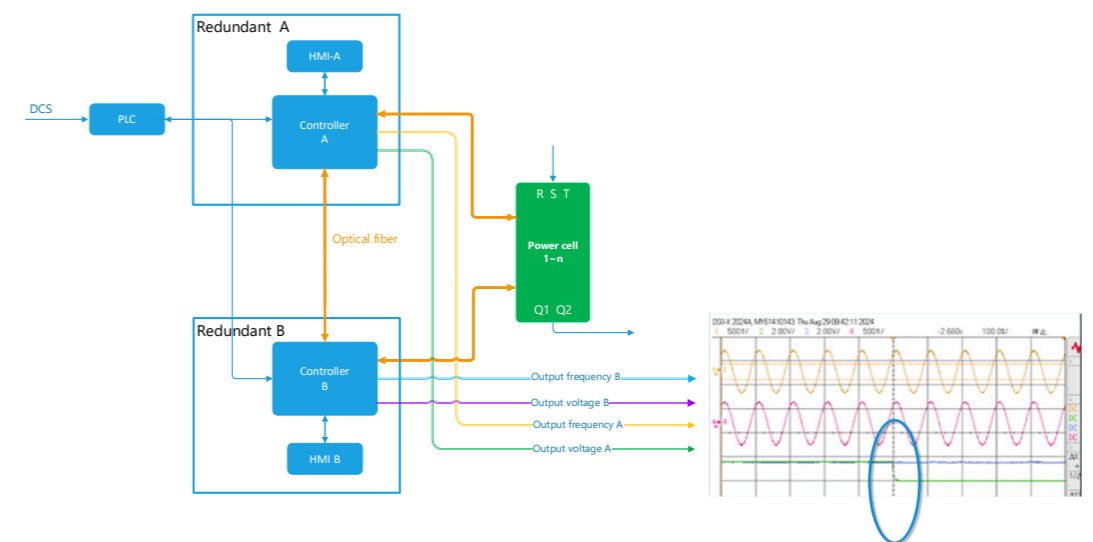

The final project scheme shall be based on the technical agreement signed between both parties.

Standard Wiring Diagram

Interface diagram of standard manual one-for-one power frequency bypass scheme

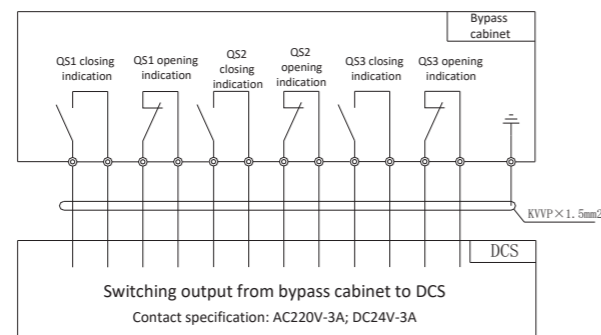
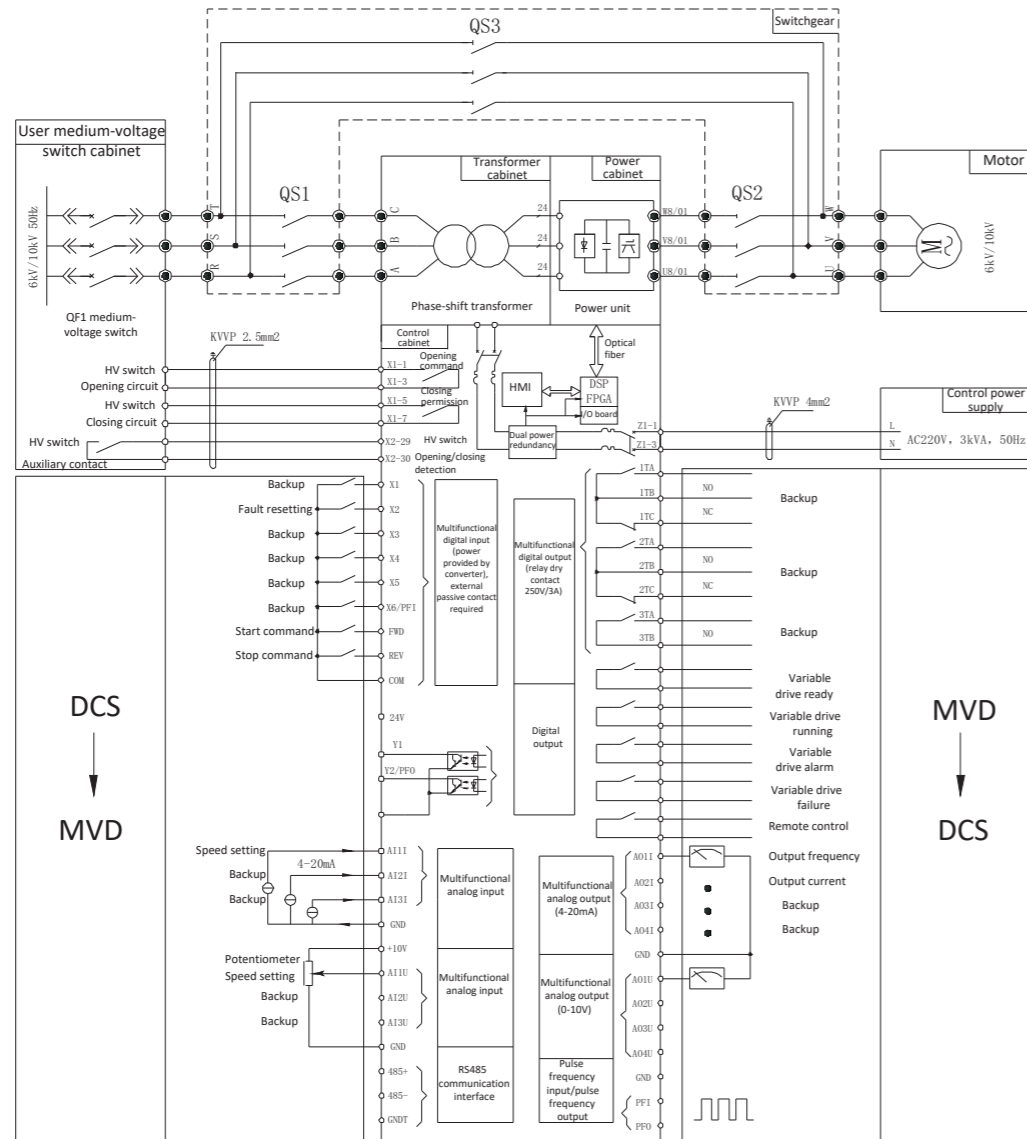

Interface diagram of standard automatic one-for-one power frequency bypass scheme

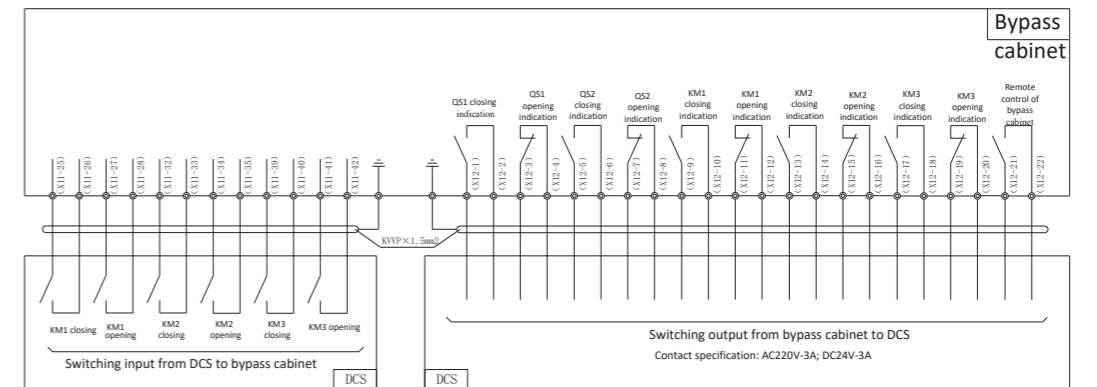
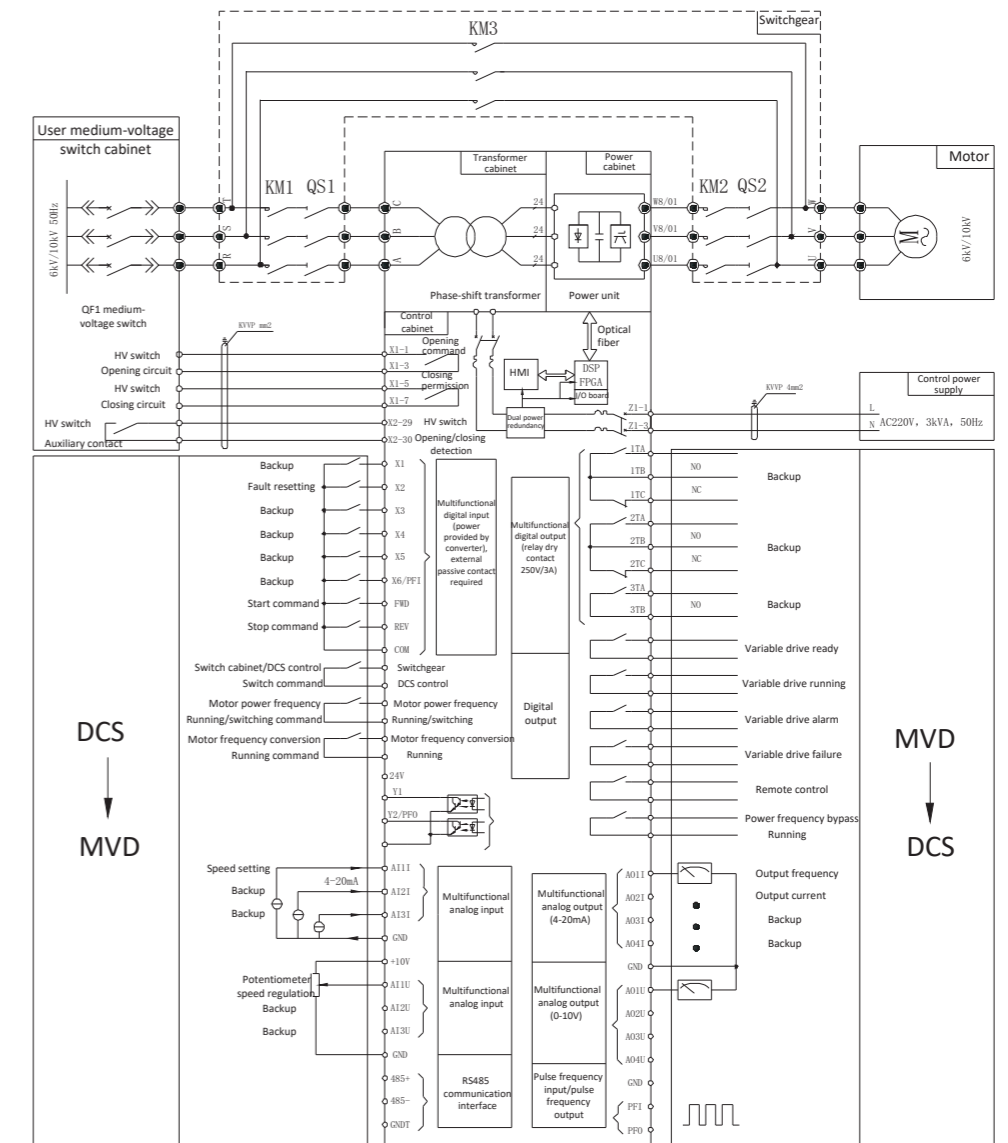

✘ The above are user interface signals for standard solutions and are for reference only. For specific projects, the project information shall prevail.

Technical Parameters

Content		Parameters	Remarks
Input	Rated input voltage	3~13.8kV ± 10%	
	Rated input frequency	50/60Hz, ±5%	
	Voltage fluctuation	-20% ~ +15% full load, derate -35%~20%	
	Power factor	≥0.96	
Output	Rated output voltage	3~13.8kV	For higher voltage and higher power, please contact us by phone call
	Output current rating	25 - 2400 A	
	Output power range	160 - 40,000 kW	
	Overload capacity	120%/120s, 150%/5s, 200% immediate protection	Protection curve can be adjust
Basic performance	Inverter efficiency	98.5%	
	Frequency resolution	0.01Hz	
	Total harmonic content (THD)	3-4.16kV, THD<=4% 6-13.8kV, THD<=2%	Meeting the Chinese national standards GB14549-93 and IEEE519-1992 for power quality standards
Control interface	Display	Multilingual HMI, capable of simultaneously displaying basic electrical parameters such as input (output) voltage, current, power, power factor, as well as real-time operation status of inverters, alarm fault recording, and event recording functions	
	Setting	Multifunctional parameter settings	
	Operation	HMI, DCS, Communication, on-site operation box	
Control	Motor control mode	V/F control, V/F+PG control, SVC, Vector control+PG	
	Acceleration/ deceleration time	0.1 to 3600.0s	
	Analog input/ output quantity	3-channel analog input, 4-channel analog output Voltage type and current type can be set Input frequency, output current, and output frequency can be set Seven types can be set, including 0 (4)-20mA, 0 (2)-10V, etc.	
	Digital input/ output quantity	8-circuit digital input, 5-circuit digital output (scalable) 38 digital input functions such as internal virtual REV/FWD and forward/reverse jog can be set 52 digital output functions such as alarm/fault output and forward/reverse operation status can be set	
	Communication function	RS485, MODBUS-RTU (standard configuration) PROFIBUS-DP (optional), TCP/IP (optional), IoT(optional)	
	Control power capacity	Single phase 220VAC/3kVA, 50/60Hz, optional DC	
	Main control functions	Instantaneous power failure restart, torque increase, jump frequency, power cell bypass, speed tracking start, system self-diagnosis, and system power frequency bypass	
	Protection	Overcurrent, overload, short circuit, three-phase current imbalance, instantaneous power loss, input (output) phase loss, overvoltage, undervoltage, converter overheating, external fault shutdown (NO and NC), and power unit automatic bypass, etc.	
Environment and others	Ambient temperature/humidity	-10-40°C, 20%-95% (no condensation)	For special environment, please call for consultation
	Storage temperature	-40-70°C	
	Altitude	<2000m, derated above 2000m	
	Cooling mode	Forced air cooling, water cooling	
	Degree of protection	IP31, optional IP42	
	Application site	Indoor, no explosive or corrosive gases, no conductive dust, and no oil mist	

Model Description

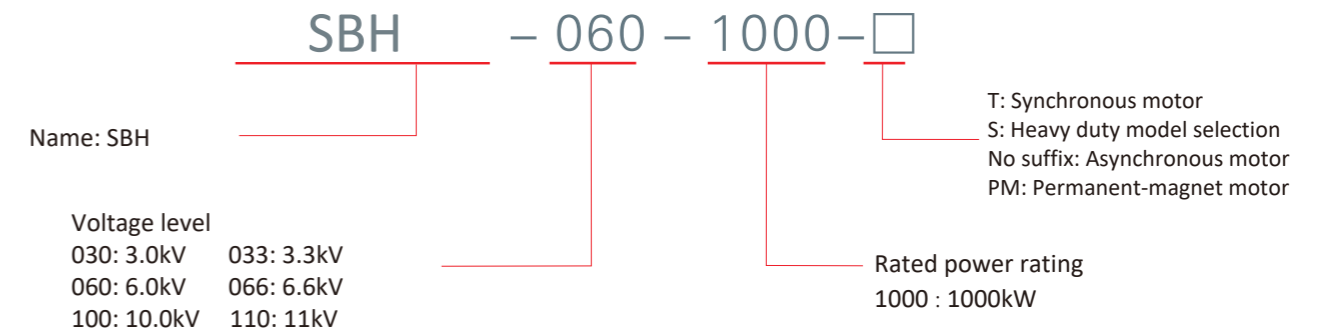

Overall Dimensions

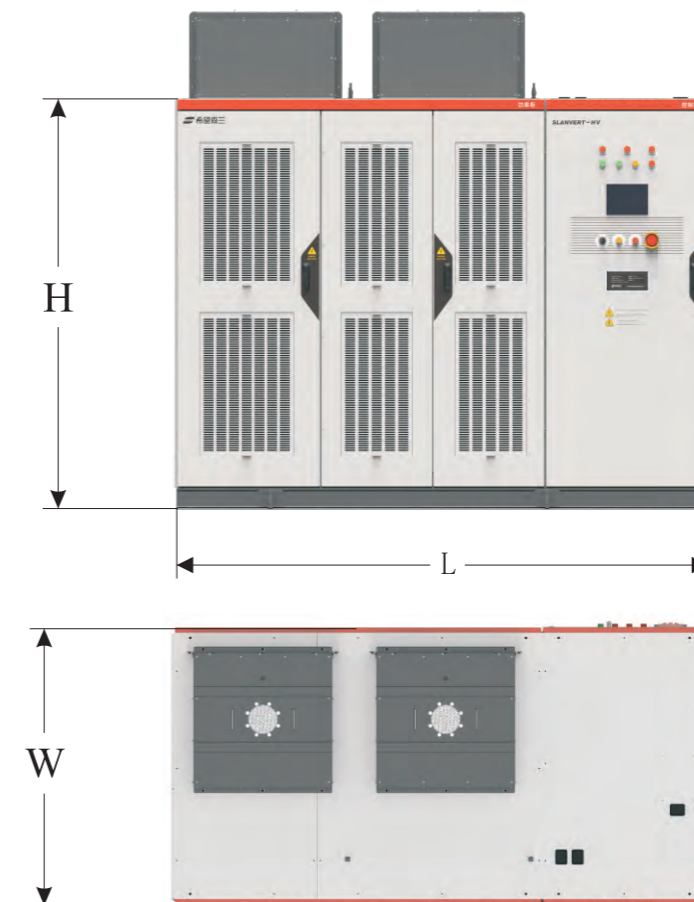

- ※ Please refer to the product specifications for details
- ※ SLANVERT can provide users with customized special medium-voltage drive
- ※ The height of the overhead blower is less than 500mm
- ※ The standard color of the cabinet is gray white (RAL7035), which can be customized as per user request.

Dimensions of SBH Series

SBH series with voltage level at 3kV

Model	Rated capacity (kVA)	Rated output current (A)	Dimension		
			L	W	H
SBH-030-160	200	39	3200	1000	2200
SBH-030-200	250	49	3200	1000	2200
SBH-030-220	275	54	3200	1000	2200
SBH-030-250	315	61	3200	1000	2200
SBH-030-280	350	68	3200	1000	2200
SBH-030-315	400	77	3200	1000	2200
SBH-030-355	450	86	3500	1000	2200
SBH-030-400	500	96	3500	1000	2200
SBH-030-450	560	108	3500	1200	2200
SBH-030-500	630	120	3500	1200	2200
SBH-030-560	700	135	3500	1200	2200
SBH-030-630	800	154	3900	1200	2200
SBH-030-710	900	171	3900	1200	2300
SBH-030-800	1000	192	4200	1300	2300
SBH-030-900	1125	216	4200	1300	2300
SBH-030-1000	1250	240	4200	1300	2300
SBH-030-1120	1400	276	4200	1300	2300
SBH-030-1250	1600	308	4600	1300	2300
SBH-030-1400	1750	345	4600	1300	2300
SBH-030-1600	2000	395	4600	1300	2300
SBH-030-1800	2250	443	4600	1300	2300
SBH-030-2000	2500	493	4900	1300	2300
SBH-030-2240	2800	552	4900	1300	2300
SBH-030-2500	3150	616	4900	1400	2300
SBH-030-2800	3500	690	4900	1400	2300
SBH-030-3150	4000	778	4900	1400	2300

※ 1. This is the overall dimensions for the unit without a bypass: the manual bypass length needs to be added on this basis;
 The capacity of the drive can be adjusted as needed;
 The overall dimensions do not include the height of the fan.

SBH series with voltage level at 3.3kV

Model	Rated capacity (kVA)	Rated output current (A)	Dimension		
			L	W	H
SBH-033-160	200	34	3200	1000	2200
SBH-033-200	250	45	3200	1000	2200
SBH-033-220	275	49	3200	1000	2200
SBH-033-250	315	55	3200	1000	2200
SBH-033-280	350	62	3200	1000	2200
SBH-033-315	400	70	3200	1000	2200
SBH-033-355	450	79	3500	1000	2200
SBH-033-400	500	87	3500	1000	2200
SBH-033-450	560	98	3500	1200	2200
SBH-033-500	630	110	3500	1200	2200
SBH-033-560	700	124	3500	1200	2200
SBH-033-630	800	140	3900	1200	2200
SBH-033-710	900	157	3900	1200	2300
SBH-033-800	1000	175	4200	1300	2300
SBH-033-900	1125	196	4200	1300	2300
SBH-033-1000	1250	219	4200	1300	2300
SBH-033-1120	1400	245	4200	1300	2300
SBH-033-1250	1600	280	4600	1300	2300
SBH-033-1400	1750	315	4600	1300	2300
SBH-033-1600	2000	350	4600	1300	2300
SBH-033-1800	2250	392	4600	1300	2300
SBH-033-2000	2500	437	4900	1300	2300
SBH-033-2240	2800	490	4900	1300	2300
SBH-033-2500	3150	551	4900	1400	2300
SBH-033-2800	3500	620	4900	1400	2300
SBH-033-3150	4000	722	4900	1400	2300

※ 1. This is the overall dimensions for the unit without a bypass: the manual bypass length needs to be added on this basis;
 The capacity of the drive can be adjusted as needed;
 The overall dimensions do not include the height of the fan.

Dimensions of SBH Series

SBH series with voltage level at 6kV

Model	Rated capacity (kVA)	Rated output current (A)	Dimension		
			L	W	H
SBH-060-160	200	20	2400	1300	2000
SBH-060-200	250	25	2400	1300	2000
SBH-060-220	275	28	2400	1300	2000
SBH-060-250	315	31	2400	1300	2000
SBH-060-280	350	35	2400	1300	2000
SBH-060-315	400	39	2400	1300	2000
SBH-060-355	450	44	2400	1300	2000
SBH-060-400	500	50	2400	1300	2000
SBH-060-450	560	56	2400	1300	2000
SBH-060-500	630	62	2400	1300	2000
SBH-060-560	700	69	2400	1300	2000
SBH-060-630	800	78	2900	1500	2000
SBH-060-710	900	88	2900	1500	2000
SBH-060-800	1000	99	2900	1500	2000
SBH-060-900	1125	111	2900	1500	2000
SBH-060-1000	1250	123	2900	1500	2000
SBH-060-1120	1400	138	2900	1500	2000
SBH-060-1250	1600	154	2900	1500	2000
SBH-060-1400	1750	173	3150	1500	2000
SBH-060-1600	2000	198	3150	1500	2000
SBH-060-1800	2250	222	3150	1500	2000
SBH-060-2000	2500	247	4300	1300	2200
SBH-060-2240	2800	277	4300	1300	2200
SBH-060-2500	3150	309	4300	1300	2200
SBH-060-2800	3500	346	5640	1500	2400
SBH-060-3150	4000	384	5640	1500	2400
SBH-060-3550	4500	439	5640	1500	2400
SBH-060-4000	5000	495	5640	1500	2500
SBH-060-4500	5600	557	5930	1800	2500
SBH-060-5000	6300	619	5930	1800	2500
SBH-060-5600	7000	693	5930	1800	2500
SBH-060-6300	7900	780	5930	1800	2500

- ※ 1. This is the overall dimensions for the unit without a bypass: the manual bypass length needs to be added on this basis;
- 2. The capacity of the drive can be adjusted as needed;
- 3. The overall dimensions do not include the height of the fan.

SBH series with voltage level at 6.6kV

Model	Rated capacity (kVA)	Rated output current (A)	Dimension		
			L	W	H
SBH-066-160	200	18	2400	1300	2000
SBH-066-200	250	23	2400	1300	2000
SBH-066-220	275	26	2400	1300	2000
SBH-066-250	315	28	2400	1300	2000
SBH-066-280	350	32	2400	1300	2000
SBH-066-315	400	35	2400	1300	2000
SBH-066-355	450	39	2400	1300	2000
SBH-066-400	500	44	2400	1300	2000
SBH-066-450	560	49	2400	1300	2000
SBH-066-500	630	55	2400	1300	2000
SBH-066-560	700	62	2400	1300	2000
SBH-066-630	800	70	2900	1500	2000
SBH-066-710	900	79	2900	1500	2000
SBH-066-800	1000	87	2900	1500	2000
SBH-066-900	1125	98	2900	1500	2000
SBH-066-1000	1250	109	2900	1500	2000
SBH-066-1120	1400	122	2900	1500	2000
SBH-066-1250	1600	140	2900	1500	2000
SBH-066-1400	1750	157	3150	1500	2200
SBH-066-1600	2000	175	3150	1500	2200
SBH-066-1800	2250	196	3150	1500	2200
SBH-066-2000	2500	219	3200	1550	2200
SBH-066-2240	2800	245	3200	1550	2200
SBH-066-2500	3150	276	3200	1550	2400
SBH-066-2800	3500	311	6850	1500	2400
SBH-066-3150	4000	350	6850	1500	2400
SBH-066-3550	4500	394	6850	1500	2400
SBH-066-4000	5000	437	6850	1500	2400
SBH-066-4500	5600	490	7150	1800	2500
SBH-066-5000	6300	551	7150	1800	2500
SBH-066-5600	7000	620	7150	1800	2500
SBH-066-6300	7900	722	7150	1800	2500

- 1. This is the overall dimensions of the no-bypass cabinet: the length of the manual/automatic bypass needs to be added on this basis;
- 2. The capacity of the drive can be adjusted as needed;
- 3. The overall dimensions do not include the height of the fan;
- 4. From the 2800KW model (including 2800KW), a current limiting cabinet needs to be added (with a width of 800mm, and the depth and height matching that of the drive).

Dimensions of SBH Series

SBH series with voltage level at 10kV

Model	Rated capacity (kVA)	Rated output current (A)	Dimension		
			L	W	H
SBH-100-200	250	15	2400	1300	2000
SBH-100-250	315	19	2400	1300	2000
SBH-100-280	350	21	2400	1300	2000
SBH-100-315	400	24	2400	1300	2000
SBH-100-355	450	27	2400	1300	2000
SBH-100-400	500	30	2400	1300	2000
SBH-100-450	560	34	2400	1300	2000
SBH-100-500	630	38	2400	1300	2000
SBH-100-560	700	42	2400	1300	2000
SBH-100-630	800	47	2400	1300	2000
SBH-100-710	900	53	2400	1300	2000
SBH-100-800	1000	60	2400	1300	2000
SBH-100-900	1125	68	2400	1300	2000
SBH-100-1000	1250	75	2400	1300	2000
SBH-100-1120	1400	84	2900	1500	2000
SBH-100-1250	1600	94	2900	1500	2000
SBH-100-1400	1750	105	2900	1500	2000
SBH-100-1600	2000	115	2900	1500	2000
SBH-100-1800	2250	130	2900	1500	2000
SBH-100-2000	2500	144	2900	1500	2000
SBH-100-2240	2800	162	3150	1500	2000
SBH-100-2500	3150	182	3150	1500	2000
SBH-100-2800	3500	205	3150	1500	2200
SBH-100-3150	4000	230	3150	1500	2200
SBH-100-3550	4500	260	4700	1300	2200
SBH-100-4000	5000	290	4700	1300	2200
SBH-100-4500	5600	324	6910	1500	2500
SBH-100-5000	6300	360	7610	1800	2500
SBH-100-5600	7000	403	7610	1800	2500
SBH-100-6300	8000	454	7610	1800	2500
SBH-100-7100	8900	510	7610	1800	2500
SBH-100-8000	10000	580	7780	1800	2500
SBH-100-9000	11250	653	7780	1800	2500
SBH-100-10000	12500	725	7780	1800	2500

- ※ 1. This is the overall dimensions for the unit without a bypass: the manual bypass length needs to be added on this basis;
- 2. The capacity of the drive can be adjusted as needed;
- 3. The overall dimensions do not include the height of the fan.

SBH series with voltage level at 11kV

Model	Rated capacity (kVA)	Rated output current (A)	Dimension		
			L	W	H
SBH-110-200	250	14	2600	1300	2000
SBH-110-250	315	17	2600	1300	2000
SBH-110-280	350	19	2600	1300	2000
SBH-110-315	400	21	2600	1300	2000
SBH-110-355	450	24	2600	1300	2000
SBH-110-400	500	26	2600	1300	2000
SBH-110-450	560	29	2600	1300	2000
SBH-110-500	630	33	2600	1300	2000
SBH-110-560	700	37	2600	1300	2000
SBH-110-630	800	42	2600	1300	2000
SBH-110-710	900	47	2600	1300	2000
SBH-110-800	1000	52	2600	1300	2000
SBH-110-900	1125	59	2600	1300	2000
SBH-110-1000	1250	66	2600	1300	2000
SBH-110-1120	1400	73	3150	1500	2000
SBH-110-1250	1600	84	3150	1500	2000
SBH-110-1400	1750	94	3150	1500	2000
SBH-110-1600	2000	105	3150	1500	2000
SBH-110-1800	2250	118	3150	1500	2000
SBH-110-2000	2500	131	3150	1500	2000
SBH-110-2240	2800	147	3150	1500	2000
SBH-110-2500	3150	165	3150	1500	2000
SBH-110-2800	3500	186	3150	1500	2200
SBH-110-3150	4000	210	3150	1500	2200
SBH-110-3550	4500	236	5300	1500	2200
SBH-110-4000	5000	262	5300	1500	2200
SBH-110-4500	5600	294	8100	1500	2500
SBH-110-5000	6300	331	8800	1800	2500
SBH-110-5600	7000	367	8800	1800	2500
SBH-110-6300	8000	420	8800	1800	2500
SBH-110-7100	8900	472	8800	1800	2500
SBH-110-8000	10000	525	9000	1800	2500
SBH-110-9000	11250	587	9000	1800	2500
SBH-110-10000	12500	656	9000	1800	2500

- 1. This is the overall dimensions of the no-bypass cabinet: the length of the manual/automatic bypass needs to be added on this basis;
- 2. The capacity of the drive can be adjusted as needed;
- 3. The overall dimensions do not include the height of the fan;
- 4. From the 4500KW model (including 4500KW), a current limiting cabinet needs to be added (with a width of 800mm, and the depth and height matching that of the drive).

Application Cases

Electricity: Induced draft fan, forced draft fan, primary air fan, booster fan, feed pump, condensate pump, and circulating water pump, etc.

- 2015.03: 12 sets of medium-voltage drive were equipped for the boiler primary air fan of the 10*350MW unit medium-voltage frequency conversion transformation project of Xinjiang Xilu Power Plant.
- 2015.07: 13 sets of dedicated medium-voltage drive for Senlan belt conveyors were equipped for long-distance belt conveyors of Xinjiang East Hope.
- 2015.08: 10 sets of medium-voltage drive were equipped for the first phase of the Cangzhou Xuyang Chemicals Thermal Power Project, including for the primary and secondary air fans, induced draft fans and water pumps.
- 2016.9: 20 sets of medium-voltage drive were equipped for the boiler feed pump of the 10*350MW unit of Xinjiang East Hope Nonferrous Metal Inhouse Power Plant.
- 2016.9: 7 sets of medium-voltage drive were equipped for the feed pumps, primary air fans and induced draft fans of the Jiangsu Datang International Rugao Cogeneration 2x12MW Project.
- 2019.12: 42 sets of medium-voltage drive were equipped for 8 projects under Guangdong Changqing (Group), including Tancheng, Shengning, Songyuan, Funing, Binxian, Huaxian, Yanjin, and Xinye.
- 2020.06: 3 sets of medium-voltage drive were equipped for the frequency conversion transformation project of the feed pump motor A of Units #1, #3, and #4 of Shenhua Yili Energy Power Plant.
- 2020.03: 17 sets of medium-voltage drive were equipped for the boiler primary air fan, secondary air fan, induced draft fan, feed pump, and initial station circulating pump loads of the Linyi Hengli Thermal Power New Heat Source Project.
- 2022.06: 5 sets of medium-voltage drive were equipped for loads such as the induced draft fan, heat network circulation pump, primary air fan, and secondary air fan of the new 30MW biomass power generation project of SEPCO Electric Power Construction Corporation.
- 2022.11: 9 sets of medium-voltage drive were equipped for the water pumps of the power generation project of Yuxi Qianyida New Energy Capacity Replacement and Upgrading Renovation Project.
- 2023.03: 8 sets of medium-voltage drive were equipped for the primary air fan of the cogeneration project in Yangzhou Chemical Industrial Park of Jiangsu Huadian Yihua Thermoelectric Power Plant.
- 2023.12: 6 sets of medium-voltage drive were equipped for loads such as the primary and secondary air fans and induced draft fans of the cogeneration project in the Xiaozhaiba Area of the Industrial Agglomeration Zone in Xifeng County, Guiyang, undertaken by Guizhou Electric Power Design Institute of PowerChina Group.



Building materials: Kiln head exhaust fan, kiln tail exhaust fan, high-temperature fan, circulation fan, slag mill exhaust fan, cement mill exhaust fan, etc.

- 2012.2: 1 set of medium-voltage drive was equipped for the kiln head fan of the 5000t/d calcium carbide slag new dry process cement production line medium-voltage frequency conversion transformation project of Xinjiang Shengxiong Energy.
- 2014.6: 3 sets of medium-voltage drive were equipped for the denitrification exhaust fans and circulation fans of Shandong Shanlv Cement.
- 2015.4: 5 sets of medium-voltage drive were equipped for loads such as the high-temperature fans, tail exhaust fans, and kiln head exhaust fans of a 5,000t/d and a 3,200t/d clinker new dry process cement production line (at an altitude of 3,000 meters) of Qinghai Huzhu Jinyuan Cements.
- 2016.11: 8 sets of medium-voltage drive were equipped for loads such as the roller press circulation fan and cement mill fan of the first-phase off-site technical transformation project of Haiyan Qinshan South Cement's Haihe Intermodal Transport and Resource Comprehensive Utilization Processing.
- 2017.1: 3 sets of medium-voltage drive were equipped for fan loads such as coal mills, cement mills, and kiln heads of the 4,000t/d new dry process cement production line (at an altitude of 3380 meters) of Qinghai Hongyang Cements.
- 2018.6: 14 sets of medium-voltage drive were equipped for the 5,000-ton clinker per day new dry process cement production line project of Huaning Yuzhu Cement.
- 2019.2: 10 sets of medium-voltage drive were equipped for the 1.2 million tons per year clinker new dry process cement production line project (at an altitude of 3,820 meters) of Lhasa Urban Construction Qilian Mountain Cement.
- 2020.7: 6 sets of medium-voltage drive were equipped for the medium-voltage frequency conversion technical transformation project of 7 major fans of Zhejiang Jinyuan Cement.
- 2021.10: 4 sets of medium-voltage drive were equipped for loads such as circulation fans, head exhaust fans, raw material mill main motors, and coal mill ventilators of the permanent magnet synchronous motor renovation project for fans of Juxian Zhonglian Cements.
- 2022.8: 7 sets of medium-voltage drive were equipped for the fans of the 5 million tons per year fine aggregate project of China Resources Cement.
- 2023.4: 13 sets of medium-voltage drive were equipped for loads such as fans, kiln main drives, ball mills, and high-temperature fans of the Fengni Solid Waste Disposal Center Project of Dongfang Hope Chongqing Cement.
- 2024.1: 5 sets of medium-voltage drive were equipped for loads such as induced draft fans, main supply fans, and boiler feed pumps of the 100,000 tons per year nano-carbon material project for medium-voltage cable shielding materials of Shandong Lianke New Materials.



Metallurgy: Dust removal fan, blast furnace blower, feed pump, humidifier water pump, lean liquid pump, ball mill, belt conveyor, etc.

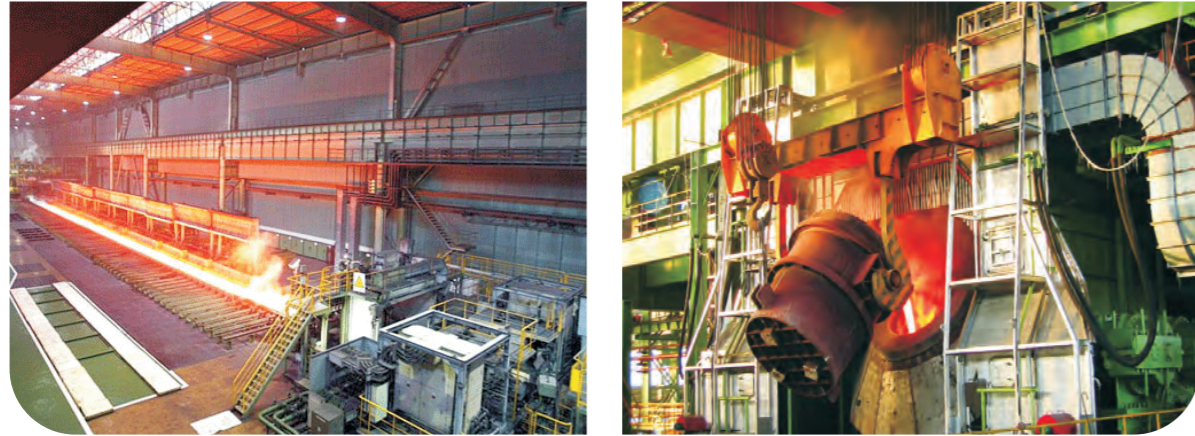

- 2013.5: 1 set of medium-voltage drive was equipped for the fans of the medium-voltage frequency conversion renovation project of Alxa League Desheng Metallurgical Materials.
- 2015.9: 4 sets of medium-voltage drive were equipped for the smoke exhaust fans of Dongfang Hope Baotou Rare Earth Aluminum.
- 2015 to 2016: 8 sets of medium-voltage drive were equipped for the pellet plant and refinery of Guangxi Shenglong Metallurgy.
- 2016.10: 3 sets of SLANVERT medium-voltage inverters were equipped for the energy-saving renovation project of Ma'anshan Iron and Steel.
- 2017.1: 7 sets of medium-voltage drive were equipped for the fan dust removal project of Shandong Rizhao Steel Plant.
- 2018.4: 3 sets of medium-voltage drive were equipped for the cold extraction fans and main extraction fans of the first-phase main extraction and cold extraction fan renovation project of Jilin Xinda Steel.
- 2019.3: 1 set of medium-voltage drive was equipped for the sintering main extraction fan of the new project of Rizhao Zhufu Industry.
- 2020.6: 2 sets of medium-voltage drive were equipped for the ferromanganese slag furnace blowers of the ferromanganese slag production line and comprehensive utilization project of Ningxia Shengyan Industrial Group.
- 2021.2: nearly 200 sets of medium-voltage drive were equipped for Chongqing Bosai Mining (Group) Co., Ltd.
- 2022.6: 3 sets of medium-voltage drive were equipped for Qian'an Iron and Steel of Shougang Corporation.
- 2022.7: 4 sets of medium-voltage drive were equipped for the fans of the ultra-low emission renovation project of Wuyang Iron and Steel's steelmaking plant.
- 2022.10: 5 sets of medium-voltage drive were equipped for loads such as lean liquid pumps, humidifier water pumps, and compressors of the 2nd bid section of Baosteel Zhanjiang Iron and Steel's 1 million-ton hydrogen-based shaft furnace project.
- 2022.12: 6 sets of medium-voltage drive were equipped for the dust removal fans of the steel slag primary treatment production line project in the steelmaking engineering of the 1,250m³ blast furnace capacity replacement and supporting technical transformation project of Beijing Shougang International Engineering Technology.
- 2023.5: 4 sets of medium-voltage drive were equipped for the dust removal fans of the 110t continuous charging electric arc furnace and refining furnace dust removal system project of Tangshan Zhongshou Special Steel.
- 2023.6: 38 sets of medium-voltage drive were equipped for the fans of Lanzhou Dongjin Silicon's 400,000-ton industrial silicon project.
- 2023.7: 5 sets of medium-voltage drive were equipped for the dust removal fans of the medium-voltage drive procurement project of Jiangsu Xugang Iron and Steel Group.
- 2023.10: 11 sets of medium-voltage drive were equipped for loads such as sodium sulfate potassium steam compressors, clinker vertical mill motors, and induced draft fans of the Xianghuangqi Lithium Resource Comprehensive Utilization Project of Inner Mongolia Ganfeng Lithium Industry.
- 2024.2: 16 sets of medium-voltage drive were equipped for the belt conveyors of the belt corridor project in the power workshop of Qian'an Jiujiang Wire and Cable Power Plant.

Petrochemical Industry: Compressor, makeup water pump, circulation pump, feed pump, fan, etc.



- 2011.12: 2 sets of medium-voltage drive were equipped for the water injection pumps of the medium-voltage frequency conversion renovation project of CNPC Liaohe Oilfield (Drilling and Production Technology Research Institute).
- 2014.5: 1 set of medium-voltage drive was equipped for the dehydrogenation unit compressor of Jiangsu Jurong Group.
- 2016.7: 1 set of medium-voltage drive was equipped for the MVR steam compressor of Yili Chuanning Biotechnology.
- 2016.11: 1 set of outdoor medium-voltage drive was equipped for the high-pressure plunger pump of the Weicheng Water Injection Station of Zhongyuan Oilfield Oil Production Plant 3.
- 2016.12: 1 set of medium-voltage drive was equipped for one-for-two gas reciprocating compressor of Beihai Gas Pipeline.
- 2016.12: 5 sets of dual redundant medium-voltage drive were equipped for the gas blower of the coking plant of Shandong Shengyang Group.
- 2016.12: 1 set of medium-voltage drive was equipped for the steam compressor of Heilongjiang Quanlin Ecological Agriculture.
- 2017.3: 3 sets of medium-voltage drive were equipped for the primary and secondary air fans and induced draft fans of the aromatics extraction unit of Sinopec.
- 2018.4: 5 sets of dual redundant medium-voltage drive were equipped for Hebei Xinhai Chemical Group.
- 2019.4: high-power medium-voltage frequency conversion soft starter was installed for the 7750kW refrigerant compressor of the 50x104Nm³/d LNG project of Ningxia Yanchi Xinkeyuan Energy Utilization Co., Ltd. to achieve smooth and stable startup of the high-power motor with the SVG function configured. After the motor startup and switching were completed, the frequency conversion soft starter dynamically compensated reactive power to the power grid.
- 2022.4: 1 set of medium-voltage drive was equipped for the 16000KW refrigerant compressor and 1 set of medium-voltage drive was equipped for the 8900KW synthetic gas compressor of Xinpengnan Coking.
- 2023.3: 7 sets of medium-voltage drive were equipped for the compressors of the medium-voltage drive procurement project of Offshore Oil Engineering Co., Ltd.
- 2023.3: 8 sets of medium-voltage drive were equipped for the water injection pumps of the medium-voltage frequency conversion device bidding project of Sinopec.
- 2023.4: 11 sets of medium-voltage drive were equipped for loads such as fans and water pumps of the 3 million tons/year coking integration and upgrading supporting project of Inner Mongolia Junzheng Energy & Chemical.
- 2023.6: 15 sets of medium-voltage drive were equipped for the feed pumps of the new project of Hulunbeier Northeast Fufeng Biotechnologies.
- 2023.10: 9 sets of medium-voltage drive (including dual thermal redundancy) were equipped for the oil pumps of the 1.6 million tons hydrogenated white oil refining project of Shandong Shengxing Chemical.

Equipment manufacturing: Test power supply, etc.

- 2012.2: 1 set of medium-voltage variable frequency test power supply was equipped for the water pump test bench of the medium-voltage variable frequency test power supply project of Jiangsu Zhenjiang Zhenghan Industrial.
- 2012.10: 8 sets of medium-voltage drive were equipped for the 100MW hydraulic press pump station of the nuclear power equipment manufacturing and testing system of Yantai Taihai Manuer Nuclear Power Equipment.
- 2013.5: one set of medium-voltage variable frequency test power supply with maximum output current of 600A was provided for the compressor test bench of Johnson Controls Central Air Conditioning Compressor Test Power Supply Project.
- 2014.4: 1 set of medium-voltage frequency conversion test power supply was equipped for the drive cigarette lighting equipment test bench of the National Water Pump and System Engineering Research Center Test Power Supply Project of Jiangsu University.
- 2016.4: 1 set of medium-voltage drive was equipped for Hangzhou NAC Co., Ltd.
- 2016,12: 1 set of medium-voltage variable frequency test power supply was equipped for the testing platform of Changzhou Pacific Electric Power.
- In Dec 2016.12: one set of (input 380V, output 10000V) medium-voltage variable frequency test power supply was equipped for the laboratory medium-voltage test power supply project of Regal Electric Appliances (Yueyang).
- 2017.3: 1 set of medium-voltage variable frequency test power supply was equipped for the compressor test bench of Johnson Controls Central Air Conditioning Compressor Test Power Supply Project.
- 2018.4: 1 set of medium-voltage variable frequency test power supply was equipped for the test power supply project of Hefei Huasheng Pumps & Valves.
- 2020.3: 2 sets of medium-voltage variable frequency test power supplies were equipped for the testing platform of the test center of Ping'an Electric.
- 2021.7: 1 set of medium-voltage variable frequency test power supply was equipped for the motor comprehensive intelligent experimental system project of Tianjin Shenhua Weiye.
- 2023.7: 1 set of medium-voltage frequency conversion soft starter was equipped for the test water pump of the medium-voltage water pump test platform project of Shenyang Industrial Pump Manufacturing.
- 2023.12: 1 set of medium-voltage drive was equipped for the compressor test power supply of the MVR turbo compressor test platform drive project of Hunan Lixing Power Technology.



Municipal industry: Domestic water pump, industrial water pump, heating, etc.

- 2013.12: 2 sets of medium-voltage drive were equipped for the lifting pumps of the transformation project of Yantai Menlou Reservoir Lifting Pump Station.
- 2015.11: 4 sets of medium-voltage drive were equipped for the water supply pump in the east of the city of Wu'an Water Plant West District Water Source Replacement Project in Handan, Hebei.
- 2015.10: 6 sets of medium-voltage drive were equipped for the water supply pump of the Water Supply Project of Textile Industrial Park in Aksu South Industrial Park, Xinjiang.
- 2016.11: 4 sets of medium-voltage drive were equipped for the water transmission project of Golmud Industrial Park (at an altitude of 2,800 meters).
- 2016.11: 17 sets of medium-voltage drive were equipped for loads such as heat network drain pumps, heat network circulation pumps, and heating circulation pumps of the Xibaipo Heat Utilization Project in Shijiazhuang Xiling Heating.
- 2019.10: 5 sets of medium-voltage drive were provided for the water pumps of the concentric new district central heating expansion project of the Housing and Urban-Rural Development Bureau of Tongxin County.
- 2020.4: 6 sets of medium-voltage drive were equipped for the third-stage booster pump station project of the water pipeline project for ecological restoration and comprehensive environmental management in the key coal mining subsidence areas of Yiqi.
- 2021.10: 8 sets of medium-voltage drive were equipped for the quality improvement project of the strategic water source in the Jiaodong Peninsula of Weifang Xiashan Reservoir Management Service Center.
- 2022.5: 9 sets of medium-voltage drive were equipped for the secondary pressure pumps of the Sangani Reservoir Project in Zimbabwe, Africa.
- 2022.11: 6 sets of medium-voltage drive were equipped for the water pumps of the charcoal ink factory pressure separation station project in Kongcun Town, Pingyin County, Shandong Province, by Shandong Luqiao Group. In July 2023. 4: sets of medium-voltage drive were equipped for loads such as circulation fans, primary and secondary air fans of the 116MW hot water boiler new construction project of Zhaodong Housing and Urban-Rural Development Bureau.
- 2023.08: 8 sets of medium-voltage drive were equipped for the water pumps of the new relay pump station project of Changli West-to-East Heat Transmission Project.
- In January 2024, 1 set of medium-voltage drive was equipped for the water pumps of the second-phase water treatment equipment of the Metelevsky Water Treatment Facility in Russia.

Shore power supply



Shore power supply

In October 2016, 1 set of shore power supply system was equipped for the 3MW shore-based power supply project of Yuanhai Wharf, Xiamen Port.

In October 2016, 1 set of shore power supply system was equipped for Jiahua Wharf, Jiaying Port, Zhejiang, which was the first shore power supply system for hazardous chemical wharves in China.

In September 2017, 3 sets of shore power supply systems were equipped for Qinzhou Port, Guangxi.

In June 2018, 2 sets of shore power supply systems were equipped for Berths CJ15# and 16# of Yuanhai Port, connected to the 10KV from 110KV Kejing Substation in Haicang District, Xiamen.

In May 2018, 1 set of shore power supply system was equipped for the low-voltage four-quadrant shore power supply project of Huaneng Fuzhou Power Plant Wharf.

In December 2020, 13 sets of shore power supply systems were added to the Hainan Jinhai Pulp & Paper Plant's Wharf Shore Power EPC Construction Project, making it the largest single ship shore power transformation project in China.

In April 2023, 1 set of shore power supply system was equipped for the shore power project of Berth 21 in Zhangwan Operation Area, Sandu'ao Port Area.

In August 2023, 2 sets of shore power supply systems were equipped for the procurement and installation project of shore power systems for Berths 105# and 129# in Xuwu Port Area.

In October 2023, 1 set of shore power supply system was equipped for the construction project of ship shore-based power supply system at Xiamen Huaxia Coal Wharf.

In January 2024, 1 set of shore power supply system was equipped for the shore power project of Berths 5# and 6# in Yangyu Operation Area, Minjiang Estuary Inner Port Area, Fuzhou Port.

High-power variable frequency soft starter

In January 2020, 1 set of one-for-two high-power medium-voltage frequency conversion soft starter was equipped for the 29000KW and 26500KW compressors of the Jiangsu Jingjing Salt Cave Compressed Air Energy Storage Project to achieve smooth and stable starting of high-power motors. The 11200KW compressor was equipped with 1 set of medium-voltage variable drive.

In May 2020, the 14000KW MRC compressor for the 400,000-ton LNG natural gas processing project of Shaanxi Xinyuan Natural Gas in Yichuan County was equipped with a high-power medium-voltage frequency conversion soft starter to achieve smooth and stable start-up of high-power motors.

In June 2020, 1 set of medium-voltage drive was equipped for the 7600kW LNG compressor of the 1 million cubic meters LNG project of Shitai Natural Gas in Etuoqeqian Banner, Inner Mongolia. The drive for this project equipped with three functions, namely speed regulation, soft start and SVG, can adjust the speed of the motor, power frequency/frequency conversion and switch without disturbance, and can dynamically compensate the reactive power to the power grid when the motor operates at power frequency.

In November 2022, 1 set of medium-voltage frequency conversion soft starter was equipped for the 16500KW, 9500KW, and 2000KW compressors of the compressor unit in the innovative demonstration project of Tongwei County Compressed Air + Lithium Battery Combined Grid-Side Shared Energy Storage Power Station, Dingxi City, Longxi New Energy, China Power Investment Xinjiang Energy Chemical Group.

In November 2022, 1 set of medium-voltage frequency conversion soft starter was equipped for the 27800KW compressor of the 400,000-ton liquefied natural gas co-producing 1 million cubic meters high-purity helium project of Ningxia Tianlifeng Energy Use.

In April 2023, 1 set of medium-voltage frequency conversion soft starter was equipped for the 11250KW compressor of the natural gas comprehensive utilization project of Zhongsheng Guojin (Daqing) Energy Technology.

In August 2023, 1 set of medium-voltage frequency conversion soft starter was equipped for the 15000KW LNG compressor of the 1 million cubic meters LNG project of Inner Mongolia Tianlifeng Gas.

Service and Support



With a strong marketing and service network covering 31 provinces, municipalities, autonomous regions in mainland China, as well as Asia, Europe, and America, SLANVERT has established branch offices in Indonesia (Jakarta), Malaysia, Vietnam, Singapore, and Hong Kong. We provide our customers with unique "SLANVERT Steward Type Services", encompassing pre-sale technical consultation and solution design, in-sale installation and commissioning, and after-sale training, maintenance, and repair services. The SLANVERT professional sales and service team are always ready to serve you!

SLANVERT promises to continue providing you with the highest quality service for our products, regardless of whether they are within the warranty period!

Service: 24x365 hours!